

# HYBRID STEPPING MOTOR SPECIFICATION

**DIMENSIONS unit=mm**

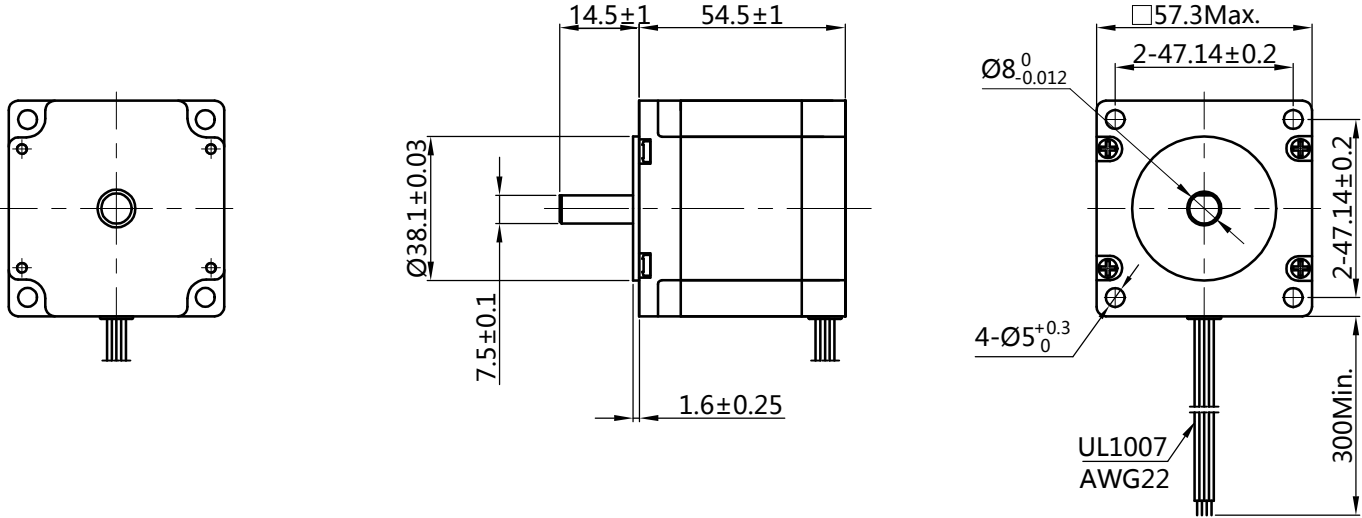

**Wiring Diagram**

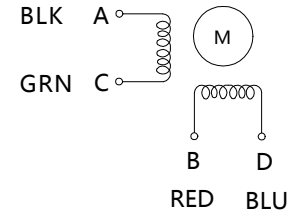

**Exciting Sequence vs. Direction of Rotation**

STEP	A	B	C	D	
1	+	+	-	-	↓ CW ↑ CCW
2	-	+	+	-	
3	-	-	+	+	
4	+	-	-	+	

**Clockwise view from mounting side**

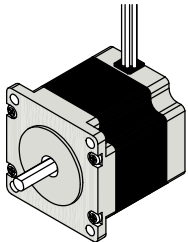

1、 Number of Phase	2				
2、 Step Angle	1.8° deg.				
3、 Rated Voltage	2.5 V				
4、 Rated Current/Phase	2.8 A ( Peak Value )				Email: sales@besfoc.com
5、 Phase Resistance	0.9 Ω±0.1(20°C)		REV.	REVISION RECORD	DATE
6、 Phase Inductance	2.5 mH±20%(1kHz 1V RMS)		DESIGN	YY 2020.06.29	Changzhou BesFoc Motor Co., Ltd www.besfoc.com
7、 Holding Torque	12.6 Kg.cm		STANDARD		
8、 Insulation Class	B ( 130° ) ; 80K Max.		TECHNOLOGY		
9、 Weight	0.7 kg		CHECK		
<b>Specifications</b>		<b>Comment</b>		<b>Specification</b>	
		APPROVE			

TITLE	STEPPING MOTOR				
DWG.NO.	BF57HS56-2804-13				
MATERIAL		ECN SIGN	✳	SIZE	A4
REV.	A	SCALE	1:2	SHEET	1 of 1