

混合式步进电机规格书

HYBRID STEPPING MOTOR SPECIFICATION

外形图 (DIMENSIONS) unit=mm

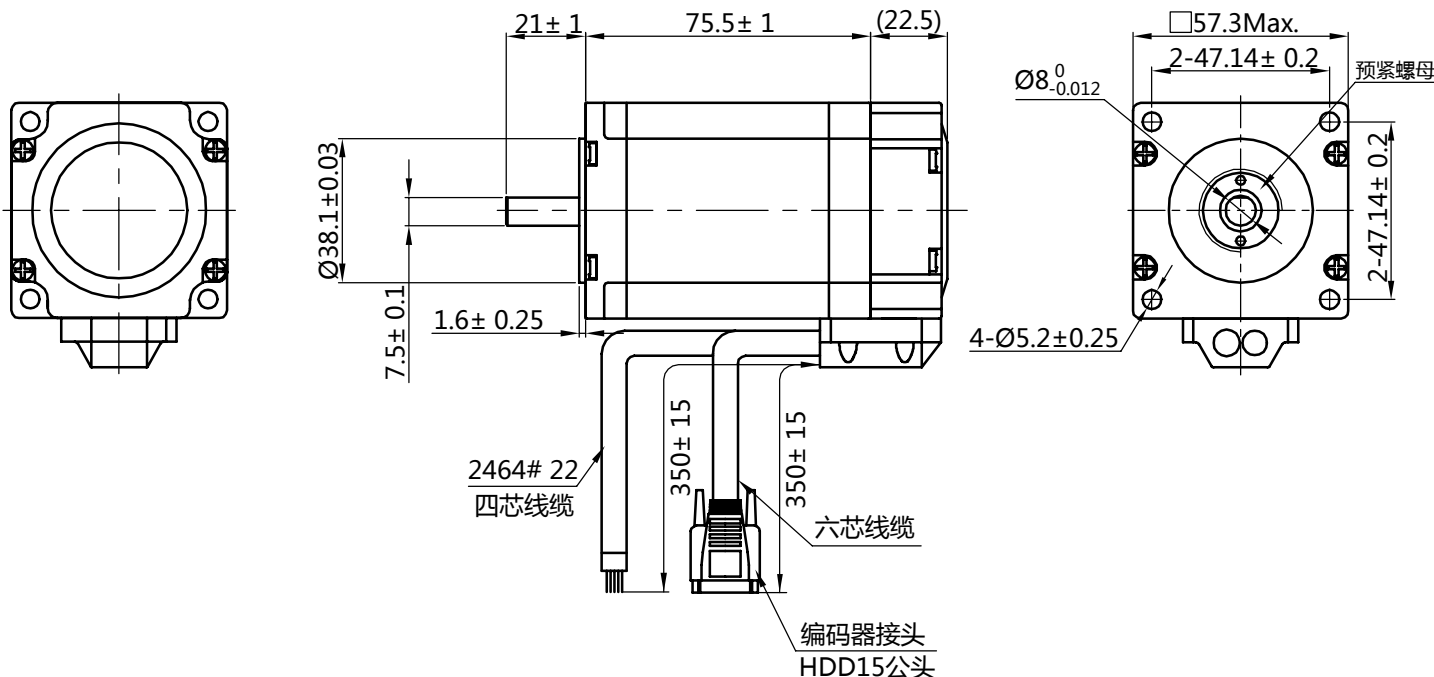

电气原理图

Wiring Diagram

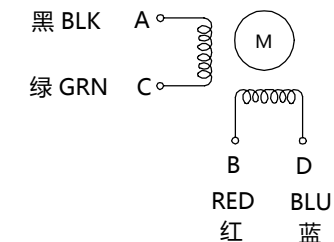

励磁顺序vs.旋转方向

Exciting Sequence vs. Direction of Rotation

STEP	A	B	C	D	
1	+	+	-	-	CCW ↑
2	-	+	+	-	
3	-	-	+	+	
4	+	-	-	+	

从安装面看为顺时针方向

Clockwise view from mounting side

编码器连接器引线颜色

Encoder Wiring Diagram

EA+	Encoder A phase input+	BLACK 黑
EA-	Encoder A phase input-	BLUE 蓝
EB+	Encoder B phase input+	YELLOW 黄
EB-	Encoder B phase input-	GREEN 绿
Vcc	Encoder Voltage(+5V)	RED 红
EGND	Encoder Grand(0V)	WHITE 白

1、相数 Number of Phase	2	注: 1.电机装1000线编码器 2.黑色端盖 Re : 1. motor with 1000ppr encoder	版本	变更内容	日期
2、步距角 Step Angle	1.8° deg.		REV.	REVISION RECORD	DATE
3、额定电压 Rated Voltage	2.52 V		设计	YY 2020.12.25	Changzhou BesFoc Motor Co., Ltd
4、额定电流/相 Rated Current/Phase	4.2 A (峰值 Peak Value)		标准化		www.besfoc.com
5、相电阻 Phase Resistance	0.6 Ω ± 0.1(20°C)		工艺		规格书 Specification
6、相电感 Phase Inductance	2 mH ± 20%(1kHz 1V RMS)		审核		
7、保持力矩 Holding Torque	21 Kg.cm		CHECK		
8、绝缘等级 Insulation Class	B (130°) 温升 80K Max.		批准		
9、重量 Weight	1.1 kg		APPROVE		
规格 Specifications		备注 Comment			

品名	步进电机			
TITLE	STEPPING MOTOR			
图号	BF57HSN21			
DWG.NO.				
材料	变更标识	SIZE	A4	
MATERIAL	ECN SIGN	1:2	页	1 of 1
版本	A	比例	SCALE	SHEET